

High-Temperature Cooling & Low-Temperature Heating AC System Evaluation of energy saving in an office in Tokyo

Katsuhiro URANO (*), Akio SUMITA (**)

(*)2-2-7, Kitakyuhoji, Yao-shi, Osaka, 581-0071, Japan
k-urano@kimukoh.co.jp

(**)Nihon BLD.13F, 2-6-2, Otemachi, Chiyoda-ku, Tokyo, 100-0004, Japan
sumita@kimukoh.co.jp

ABSTRACT

While the efficiency of water piping central AC systems has improved greatly, improving in the efficiency of the overall system had been a problem that needed to be solved. The High-Temperature Cooling & Low-Temperature Heating AC System (WATER EXCEL) centers on using a medium temp. refrigerant, having a large temp. difference between the inlet/outlet of a heat-exchanger, having low temp. air-blow, adjusting control of OA/RA volume at the chamber room and ensuring a radiant and laminar flow. A new specification has been established “10;10;13”. We took measurements in an office building in Tokyo for one year to evaluate the energy-saving properties and comfort of this system.

New specification “(1)10;(2)10;(3)13” refers to reference temperatures for an energy transfer medium.

(1) Cold water temperature is 10°C (improved heat source efficiency by shifting from the conventional 7°C to 10°C toward middle temperature).

(2) Coil doorway difference of temperature is 10K .

(reduction in pump power by having a larger temperature difference from 5K to 10K and water volume reduction).

(3) Cooling air supply temperature is 13°C (reduction in blowing power by reducing air volume from the conventional 16°C).

1. INTRODUCTION

Reduction in energy consumption for air conditioning which comprises approximately 40% of energy consumed by an office building is an urgent issue in promotion of energy saving. With the same sense of crisis, International Energy Agency (IEA) has also been conducting “research on cooling at relatively high temperatures and heating at relatively low temperatures” at Annex59. As a member of its Japanese committee, we have developed a “Medium Temp. Refrigerant used AC System with water piping” to address both energy saving and comfort.

2. METHODOLOGIES

1. Structure of high-temperature cooling & low-temperature heating AC system

This system (hereinafter called “WATER EXCEL”) is a highly efficient water piping AC system which cools/heats air with cold/hot water in the middle-temperature range, a method that has not been used previously. It also uses less water/air supply as a heat source than past systems for air conditioning to minimize energy consumption, and enhances comfort with steam humidification and radiant and laminar flow blowing.

As a heat source unit, an air-cooled chiller was employed, and it can supply high-temperature cold water and low-temperature hot water. The air conditioner is a newly developed humidity control outdoor air treatment air conditioner and return-air treatment air conditioner. The features of these air conditioners will be explained in “5. Features of outdoor air treatment air conditioner.” As an air outlet, an “All air supplied radiant and laminar flow unit” was employed. This realizes both energy saving and a comfortable indoor environment with a low temperature of 13°C air-blow. In addition, the performance evaluation will be reported in “High-Temperature Cooling & Low-Temperature Heating AC System (Part 2).”

2. Excellent energy saving performance achieved by the specification “10;10;13”

If the cold water temperature and the hot water temperature are shifted from 7°C to 10°C and from 45°C to 35°C, respectively, the efficiency of the heat source unit is improved. Since the temperature difference from the area around the piping becomes less, the effect of a reduction in radiation loss can be expected. In addition, the pump power for water transfer can be reduced by 50% because the difference in temperature of water used becomes greater from 5°C to 10°C and so the volume of water used is reduced by half. Furthermore an air supply temperature for cooling of 16°C was changed to 13°C, a lower temperature of air-blow for air transfer. This larger temperature difference realizes an air volume reduction of 30% and also allows the blowing power to be reduced.

Figure 2-1. Conceptual diagram comparing the spec “10;10;13” and the conventional spec “7;5;16”

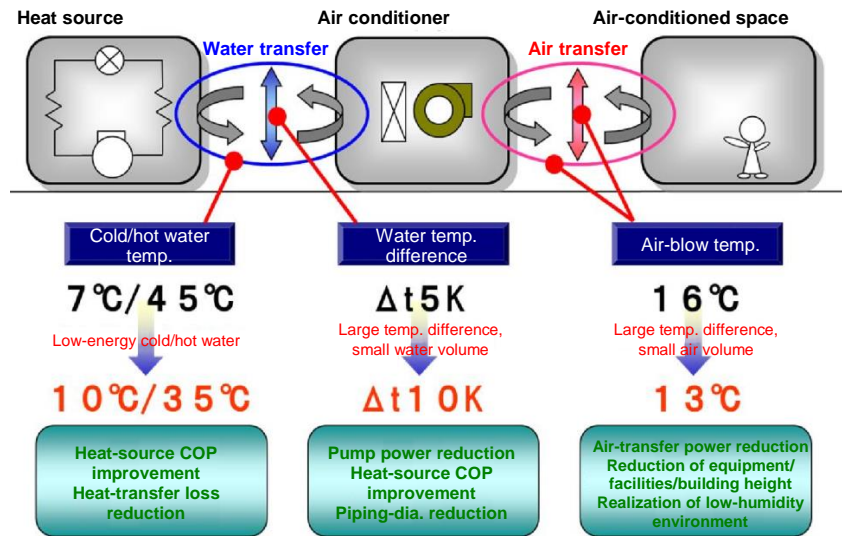

3. Multi-row heat exchangers and wind speed optimization

Oval pipe heat exchangers, which have less air resistance and higher efficiency, are mounted in multiple rows. In addition, since the specification “10;10;13” has 70% less air volume, the air resistance is 28% less. This is a heat exchanger which realized both an improvement of heat transfer efficiency and reduction of blowing power.

Figure 3-1. Example of the spec “10;10;13”

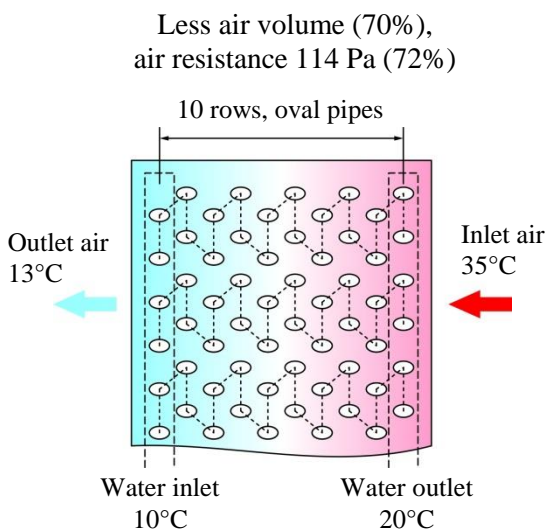
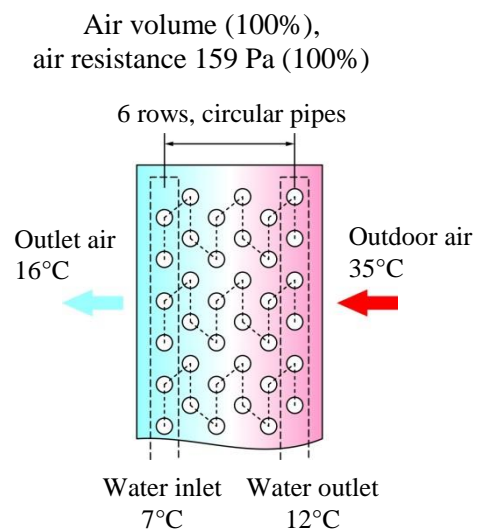

Figure 3-2. Example of the conventional spec



4. Improvement of COP of heat source unit

The spec “10;10;13” greatly improves the efficiency of the air-cooled chiller of the heat source unit. One such example of improvement is shown in Table 4-1. Comparing the 100% load factor with that of the conventional specification, COP improves by 21.5%. In addition, it improves more for the 50% load factor. Highly efficient operation is available throughout the operating range.

Table 4-1. COP comparison example of air-cooled chiller

	Spec “10;10;13”			Conventional spec.
Outdoor air (°C)	35			20
Load factor (%)	100	59	50	100
Inlet water temp. (°C)	10			7
Outlet water temp. (°C)	20			12
Water temp. difference (K)	10			5
Air supply temp.	13°C low temp. of air-blow			16°C air-blow
COP	4.01	5.15	8.67	3.30

5. Features of outdoor air treatment air conditioner

The EXCEL original mixing chamber allows the humidity control outdoor air treatment air conditioner to fully demonstrate its functions and performance and be installed in a compact machine room, and the serviceability is also taken into account.

Functional features

- CO₂ control and the adjusting control of OA/RA volume at the chamber room is executed by the automatic proportional control of the outdoor-air damper and the return-air damper.
- The outdoor-air damper is fully opened if the automatic control judges outdoor-air cooling to be possible.
- In the chamber-type machine room, no duct to the humidity control outdoor air treatment air conditioner is required so that space can be saved. In addition, it is possible to fully mix outdoor air and return air.
- The front-open insulated door can be fully opened for maintenance.
- Winter-time outdoor air can be utilized for outdoor-air cooling by mixing it with return air.

Figure 5-1. EXCEL original mixing chamber and humidity control outdoor air treatment air conditioner

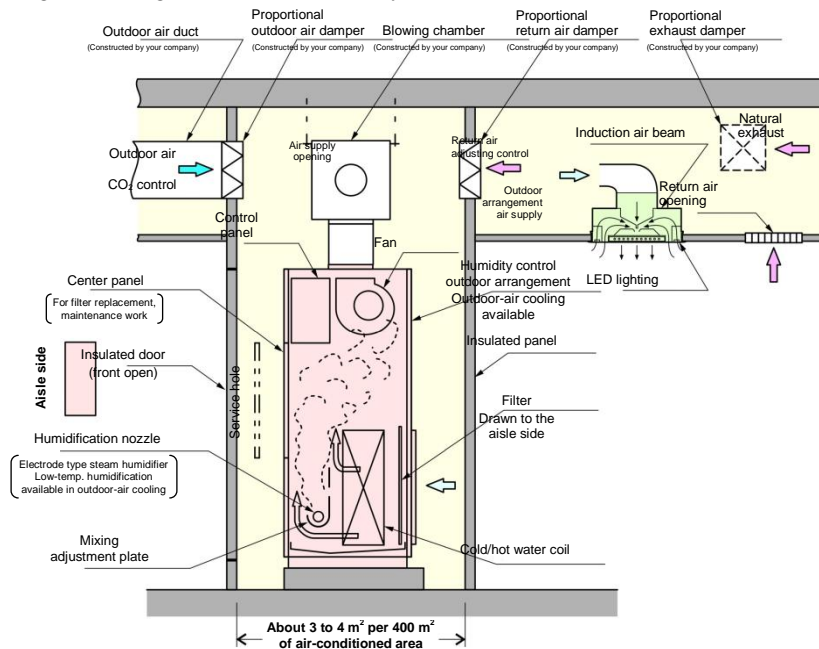

6. All air supplied radiant and laminar flow unit

The feature is that indoor air is induced and reheated by utilizing the air supply pressure from the air conditioner to cool/heat the radiation plate to radiate heat from the panel opening. In addition, laminar flow blowing eliminates any indoor draft and temperature irregularity for a uniform indoor environment, so that comfort can be improved.

The air outlet, to which 16°C air-blow had inevitably been applied for preventing dew condensation, was changed to an inducing structure to mix air with indoor air to keep the blowing temperature higher than a dew point, and this realized low-temperature blowing with a large temperature difference.

7. AC equipment and measurement system

Measurements were made at the office on the 13th floor of the Nippon Building near Tokyo Station in Japan. The floor area is 405 m², and 35 people belong to the office. The structure of the AC equipment is shown in Figure 1-1.

The arrangement of the equipment is shown in Figure 7-2. Air supply from the humidity control outdoor arrangement comes from the two all air supplied radiant and laminar flow units to each span. In addition, since ducts are connected from the meeting room and the drawing room to the FCU, air is mixed with return air and supplied to the room inside. A one-span air conditioner is installed in each span to control the room temperature in the area. If the room temperature meets the temperature setting, the blowing is stopped to reduce blowing power. The all air supplied radiant and laminar flow unit allows for a uniform indoor temperature environment only with the air supply that has a humidity control outdoor arrangement.

Figure 7-1. Appearance of Nippon Building



Figure 7-2. Floor plan of Tokyo Office

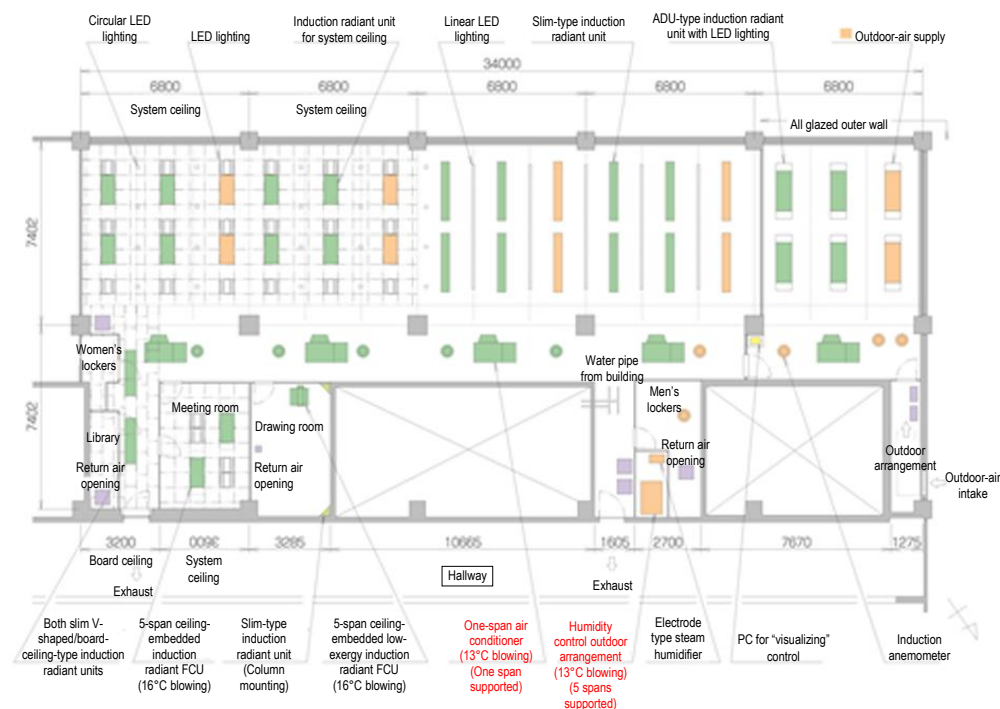

The specifications of the AC equipment are shown in Table 7-1.

Table 7-1. AC equipment items

	Specifications			Quantity
	Air volume (m ³ /h)	Cooling capacity (kW)	Heating capacity (kW)	
Humidity control outdoor arrangement	3000	39.9	24.4	1
One-span air conditioner	800	5.33	2.58	5
Ceiling embedding FCU	510	2.84	2.57	1
Radiant and laminar flow FCU	200	0.80	0.60	2
Air-cooled HP chiller	—	106	140	1

	Humidification capacity (kg/h)	Quantity
Electrode type steam humidifier	23.0	1

The installation conditions of measurement instruments are shown in Figure 7-3. The amount of heat consumption is measured by installing water volume sensors, inlet water temperature sensors, outlet water temperature sensors and calorimeters in all of the AC equipment. For the amount of power consumption, the values of all of the pieces of equipment are measured with a current transformer (CT) installed in the power cables of all of the equipment and a multimeter. Building Energy Management System (BEMS) records the measured data as needed.

Figure 7-3. System diagram

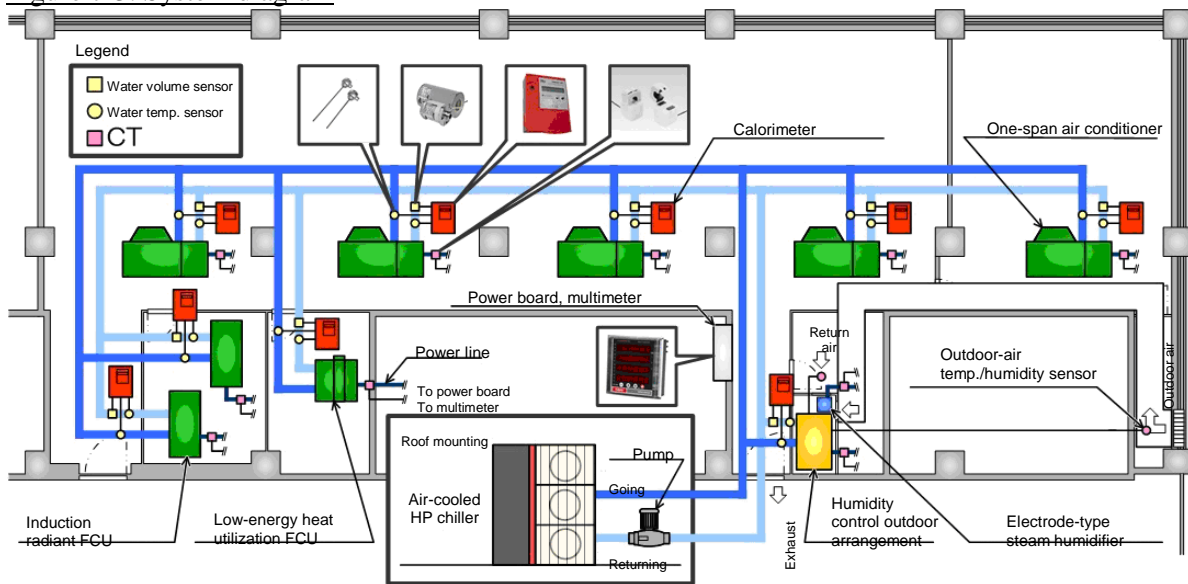

The method of measuring the power consumption of the HP chiller is explained here. Since this office is part of a large-scale building, an independent heat source unit cannot be installed there. Therefore a method of calculation in which various measured conditions were entered in the actual machine characteristics calculation program of the HP chiller was executed. The flow is shown in Figure 7-4. In addition, for evaluating the reliability of the program, the actual machines were tested to confirm the indication of the correct values.

Figure 7-4. Power consumption calculation of HP chiller

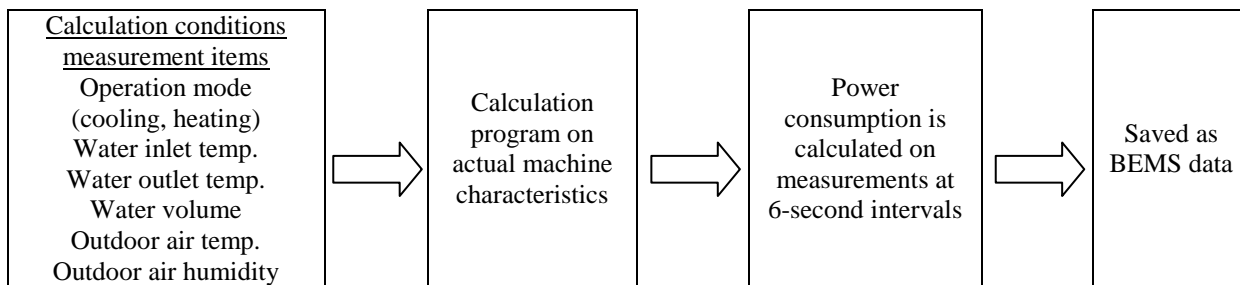

3. RESULTS AND DISCUSSION

Regarding actual measurement, the results obtained from July 2011 to June 2012 were compared with the trial calculation values of the conventional system in Figure 8-1 and Table 8-1. The result showed that the actual measurement value of power consumption in each month is less by far. Particularly the amount of reduction in the SA fan and the HP chiller is drastic. This can be judged to be the effect of the lower air volume, the high-temperature cooling and the low-temperature heating. A large proportion of the increased actual measurement values is the power consumption of humidification in winter-time. This is because an electrode-type steam humidifier was employed in order to stably keep an indoor relative humidity of 45% or more. The trial calculation of the conventional system includes a vaporizing humidifier, which is generally often used and included in the HP chiller. Considering the COP, it is easily inferred to be less than the actual value of the electrode-type steam humidifier.

However, comparing the totals of AC equipment for a year, “10;10;13” consumed 15,730 kWh, while “7;5;16” consumed 31,300 kWh; therefore there was a reduction of about 49.7%.

Figure 8-1. Graphs comparing power consumption

Trial calculation values of conventional system in Tokyo Office

Actual measurement values of WATER EXCEL in Tokyo Office

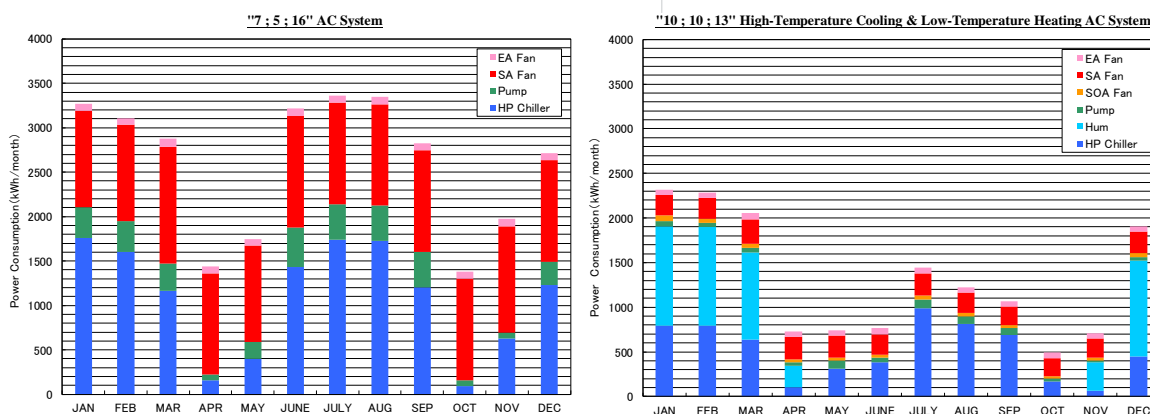

Table 8-1. Charts comparing power consumption

(kWh)

Season	Winter, 2012			Spring, 2012			
Month	JAN	FEB	MAR	APR	MAY	JUNE	
7;5;16	3270	3110	2880	1450	1750	3220	
10;10;13	2320	2290	2050	730	740	760	
Comparison	70.9%	73.6%	71.2%	50.3%	42.3%	23.6%	
Season	Summer, 2011			Autumn, 2011		Winter, 2011	Total
Month	JULY	AUG	SEP	OCT	NOV	DEC	
7;5;16	3360	3350	2830	1380	1980	2720	31300
10;10;13	1440	1220	1070	490	710	1910	15730
Comparison	42.9%	36.4%	37.8%	35.5%	35.9%	70.2%	50.3%

Incidentally, the evaluation of energy saving in an actual office like the one performed this time requires the validation of the climate. Since a cool summer or a warm winter reduces AC load, the power consumption is also reduced. In Table 8-2, the average temperature of each month for the measurement period was compared with the average temperature of the past three decades. The result shows that the temperatures of the actual measurement period are higher in summer and lower in winter. Because of this, the climate in the actual measurement period can be judged to be proper for the evaluation of energy saving.

Table 8-2. Climate conditions in actual measurement period (°C)

Season	2012						2011					
	Winter			Spring			Summer			Autumn		Winter
Month	JAN	FEB	MAR	APR	MAY	JUNE	JULY	AUG	SEP	OCT	NOV	DEC
JULY 2011 to JUNE 2012	4.8	5.4	8.8	14.5	19.6	21.4	27.3	27.5	25.1	19.5	14.9	7.5
Average of past three decades (average year value)	5.7	6.1	8.9	14.0	18.3	21.3	25.0	26.7	23.3	18.0	12.9	8.3
Temp. difference	-0.9	-0.7	-0.1	0.5	1.3	0.1	2.3	0.8	1.8	1.5	2.0	-0.8

* Extracted from the website of the Meteorological Agency

4. CONCLUSIONS

The measurements showed that the yearly AC operating time of the Tokyo Office was 2916 hours, the actual measurement values of the AC power consumption were 38.8 kWh/m²·year (1) and 13.3 W/m² (2), and the reduced value to primary energy was 379 MJ/m²·year (3) (an equivalent of 9.76 MJ/kWh).

$$15730 \text{ (kWh/year)} / 405 \text{ (m}^2\text{)} \approx 38.8 \text{ (kWh/m}^2\text{·year)} \quad (1)$$

$$38.8 \text{ (kWh/m}^2\text{·year)} / 2916 \text{ (h/year)} \times 1000 \approx 13.3 \text{ (W/m}^2\text{)} \quad (2)$$

$$38.8 \text{ (kWh/m}^2\text{·year)} \times 9.76 \text{ (MJ/kWh)} = 378.688 \approx 379 \text{ (MJ/m}^2\text{·year)} \quad (3)$$

If this is converted to 3374 hours, which is the yearly AC operating time of the reference value in the Revised Save Energy Law announced by the Ministry of Economy, Trade and Industry, the Ministry of Land, Infrastructure, Transport and Tourism, and the Ministry of the Environment of Japan, it becomes 438 MJ/m²·year. Compared to “The reference value” for offices in the Tokyo area of 1115 MJ/m²·year, WATER EXCEL has only about 40% of the primary energy consumption, and the reduction rate is 60%.

The high-temperature cooling & low-temperature heating AC system can also be built in places other than buildings like the office building examined this time. Therefore it seems possible to contribute to energy saving in a broad range of applications.

As a reference, WATER EXCEL received the 2013 “Energy Conservation Grand Prize” promoted by the Ministry of Economy, Trade and Industry of Japan.

It has been demonstrated recently that the yearly operating load factor of many office buildings is 30% or less. That is, AC system models are still being selected with emphasis placed on their peak-time air-conditioning effect even in the present energy-saving age. Therefore, we developed a flow-rate control capable of instantaneously responding to low loads between periods by upgrading related technology, achieving a large temperature difference with the returning water temperature. This flow-rate control and humidification system with improved energy-saving performance received the WATER EXCEL 2014 “Energy Conservation Grand Prize” for two consecutive years.

2-way circuit coil

By adopting two inlet pipes and two inlet headers, a 2-way circuit coil consisting of two separate water circuit systems is incorporated, which can independently control the flow rates of the systems (Figure 9-1).

Each of the inlet pipes is provided with a small valve, and either valve is operated under a low load to perform flow-rate control. As a result, the total control range is extended (minimum 12.5%), making it possible to ensure a large water difference of Δt_{10} K between outgoing water and returning water under a low load (Figure 9-2).

Figure 9-1. 2-way circuit coil

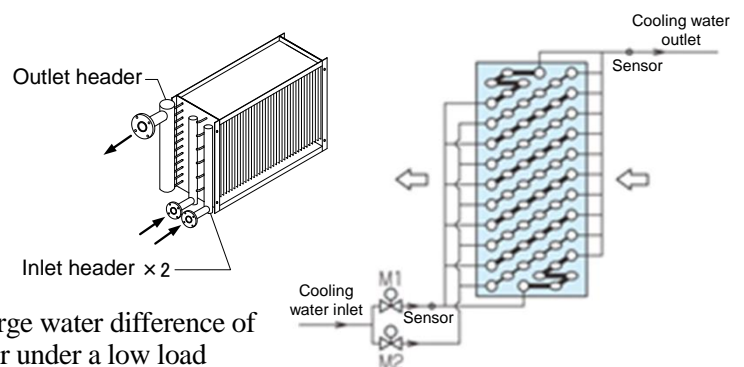
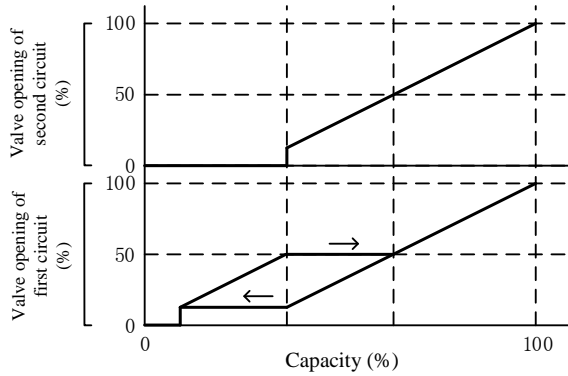

Figure 9-2. 2-way circuit valve control



Hybrid humidification

We developed a hybrid humidification system based on a vaporizing humidifier that combines a steam humidifier to cover regions in which operation with a vaporizing humidifier would be unstable. A steam nozzle is mounted at the secondary side of the vaporizing humidifier, and an electrode-type humidifier, which is safe to use, is adopted as the steam source. Stable humidification can be achieved in a wide range of regions, including low-temperature humidification, on a psychrometric diagram without causing a significant increase in power consumption (Table 9-1), because the vaporizing humidifier is operated preferentially. These two humidifiers are operated optimally with automatic control (Figure 9-3).

Table 9-1. Comparison of yearly power consumption between different humidification systems

Humidification system	Only vaporizing humidifier	Only steam humidifier	Hybrid system
Power consumption [kWh]	1,692	4,786	2,427
Ratio (assuming that vaporizing humidifier is 1)	1	2.83	1.43
Ratio (assuming that steam humidifier is 1)	0.35	1	0.51

* Estimated value at an air flow of 10,000 m³/h (amount of outdoor air: 30%) and under weather conditions of Tokyo

Figure 9-3. Hybrid humidification

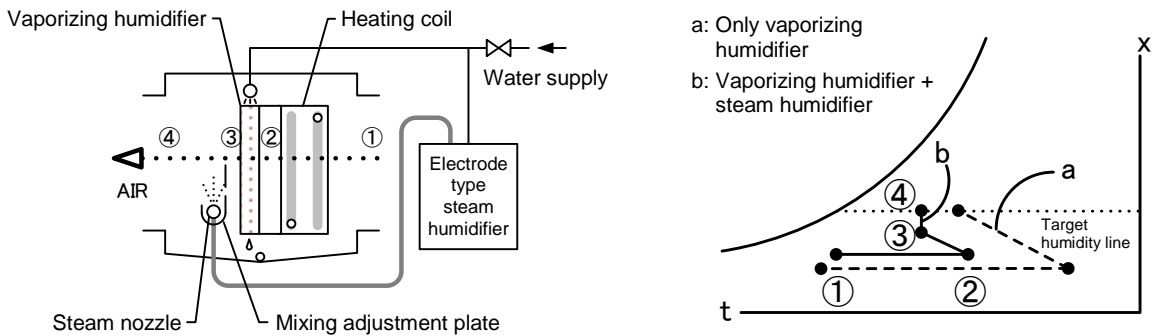

5. ACKNOWLEDGEMENT

For the actual measurement of power consumption in this study, we had technical cooperation from the Kawase Laboratory at the Graduate School of Engineering, Chiba University. We would like to express our gratitude for this.

6. REFERENCES

- 1) Notification No. 119 (fiscal 2012) of the Ministry of Economy, Trade and Industry, the Ministry of Land, Infrastructure, Transport and Tourism, and the Ministry of the Environment of Japan
Term: Office application in Tokyo area